

CPT CONNECTOR

Board-to-wire

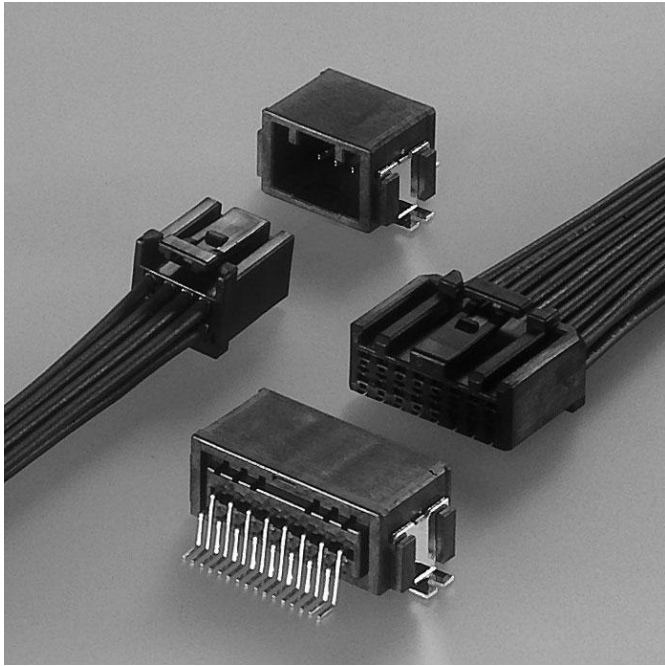

Features

● Compact design

2.0 mm pitch is realized miniaturization and low profile as the connector for automobile.

● Terminal construction

Female terminal is designed for simple box structure by having spring structure on male terminal.

Developed in pursuit of miniaturization and low profile as PC board connector for automobile.

This connector is surface mounting type connector having the spring structure on male terminal disproving the conventional concept.

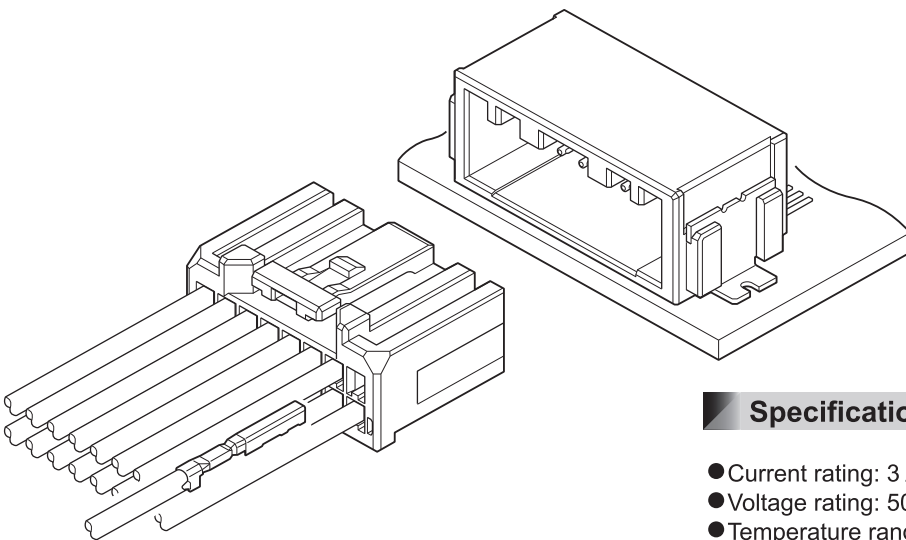

Specifications

- Current rating: 3 A AC, DC (0.3 mm², Single circuit)
- Voltage rating: 50 V AC, DC
- Temperature range: -40°C to +100°C
(including temperature rise in applying electrical current)
- Contact resistance: Initial value/ 8 mΩ max.
After environmental tests/ 16 mΩ max.
- Insulation resistance: 100 MΩ min.
- Withstanding voltage: 1,000 VAC/minute
- Applicable wire: AESX-f/ AVSS
0.3 mm²

* Compliant with ELV/RoHS2.

* Contact JST for details.

Female terminal

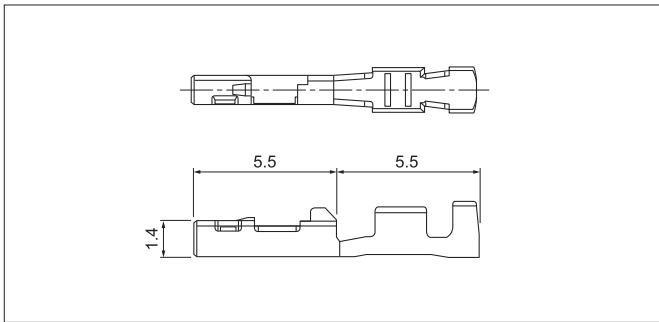

Model No.	Applicable wire range		Q'ty/reel
	Conductor (mm ²)	Insulation O.D. (mm)	
SCPT-A021GF-0.5	0.3	1.4	15,000

Material and Finish
Brass, nickel-undercoated, Contact area; gold-plated Barrel area; tin-plated

Female connector

Single row

● 2 circuits

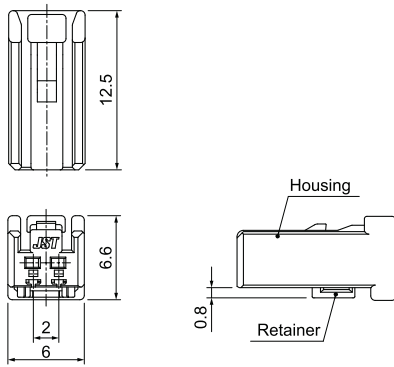

● 4 circuits

04CPT-B1-2A

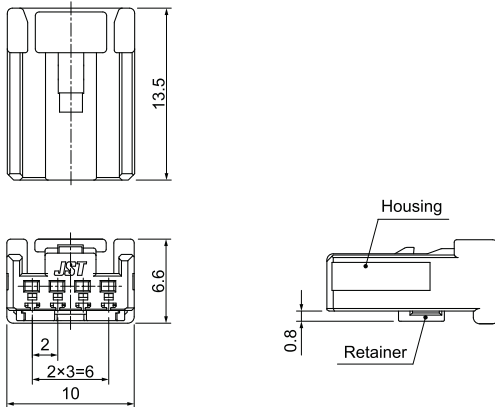

04CPT-B1-2B

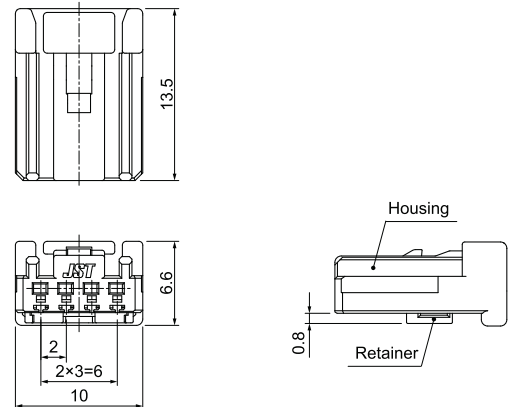

● 8 circuits

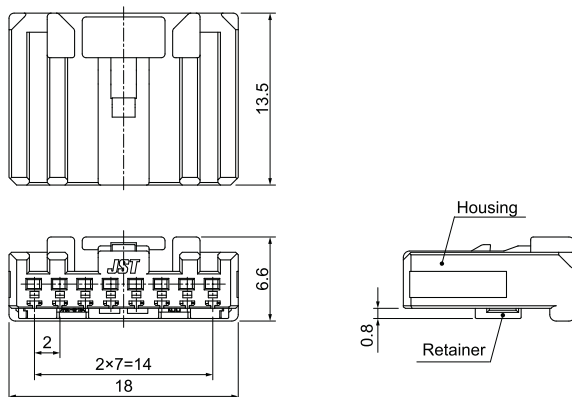

Circuits	Model No.	Q'ty/box
2	02CPT-B-2A	500
4	04CPT-B1-2A	600
	04CPT-B1-2B	
8	08CPT-B1-2A	400

Material and Finish
Housing: Glass-filled PBT, Black Retainer: Glass-filled PBT, Blue

CPT CONNECTOR

Female connector

Dual row

● 8 circuits

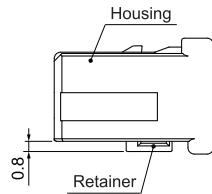
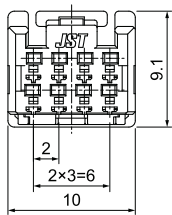
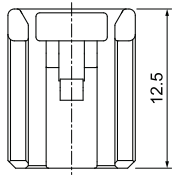

● 12 circuits 12CPT-B-2A

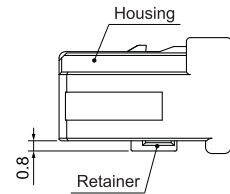
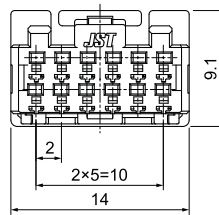
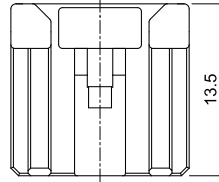

● 12 circuits 12CPT-B-2A-FL

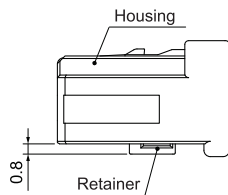
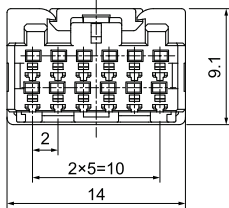
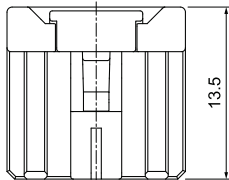

● 16 circuits

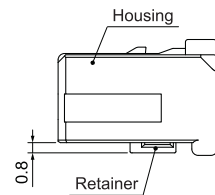
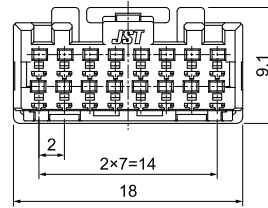
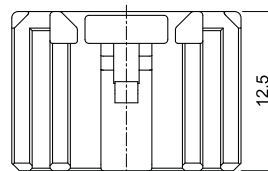

● 20 circuits

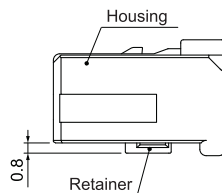
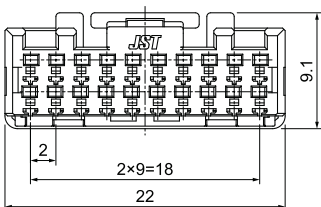
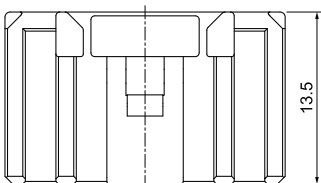

● 24 circuits

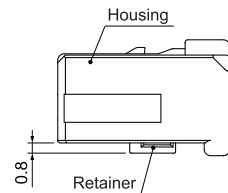
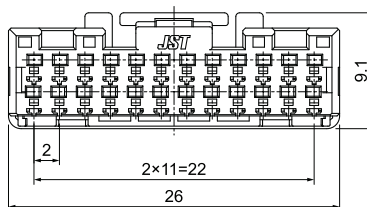
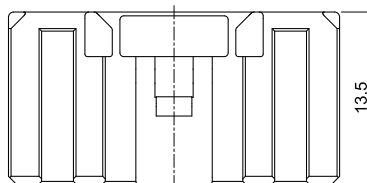

Circuits	Model No.	Q'ty/box
8	08CPT-B-2A	500
12	12CPT-B-2A	300
	12CPT-B-2A-FL	
16	16CPT-B-2A	250
20	20CPT-B-2A	250
24	24CPT-B-2A	200

Material and Finish

Housing: Glass-filled PBT, Black
Retainer: Glass-filled PBT, Blue

Male connector

Top entry type

Single row
●2 circuits

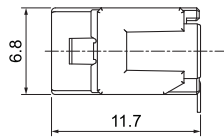
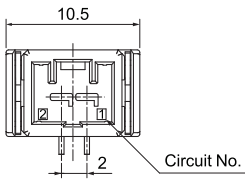
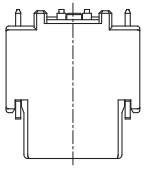

Dual row
●8 circuits

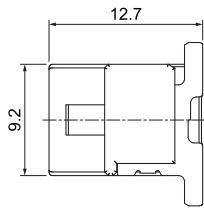
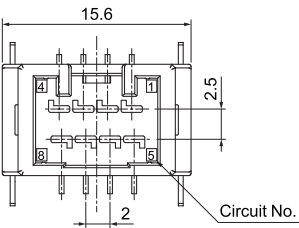
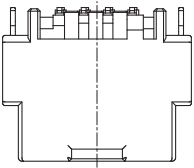

●12 circuits

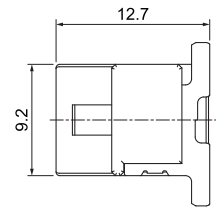
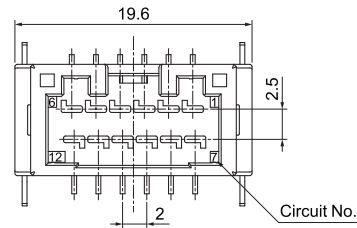
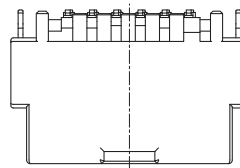

Type	Circuits	Model No.	Q'ty/reel	
Top	Single row	2	BM02B-CPTK-1A-TB	370
	Dual row	8	BM08B-CPTK-1A-TB	240
		12	BM12B-CPTK-1A-TB	

Material and Finish

Terminal: Copper alloy, nickel-undercoated,
Contact area; gold-plated
Solder tail; tin-plated (reflow treatment)
Housing: Glass-filled LCP, Black
Peg: Brass, nickel-undercoated, tin-plated (reflow treatment)

CPT CONNECTOR

Male connector

Side entry type

Single row

●2circuits

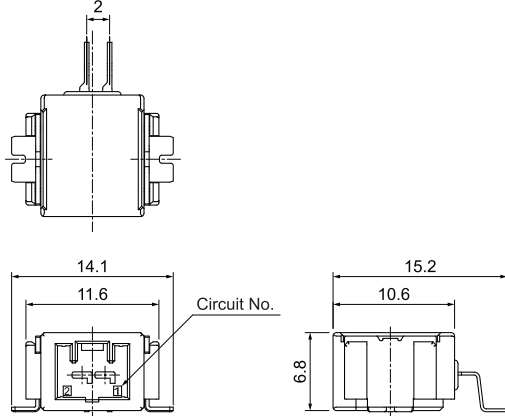

●4 circuits

SM04B1-CPTK-1A-TB

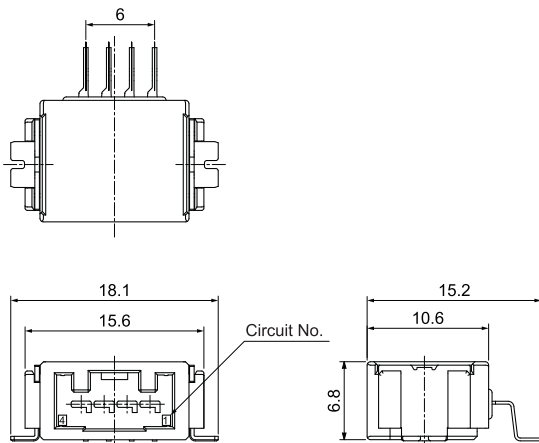

SM04B1-CPTK-1B-TB

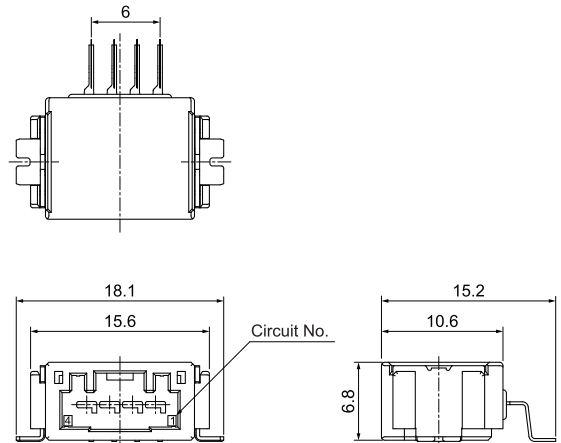

●8 circuits

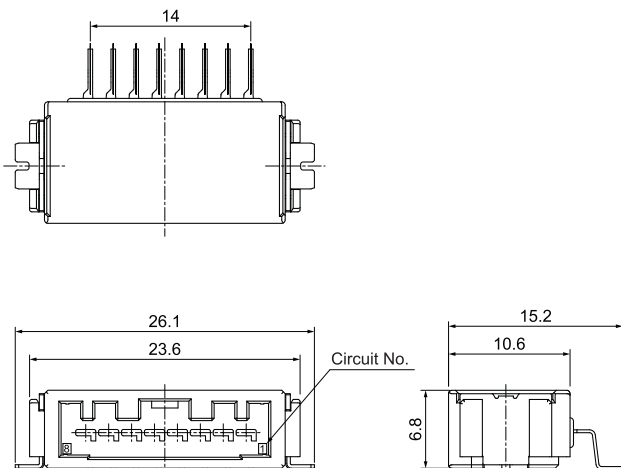

Type	Circuits	Model No.	Q'ty/reel
Side	Single row	2	500
		4	
		8	

Material and Finish

Terminal: Copper alloy, nickel-undercoated,
 Contact area; gold-plated
 Solder tail; tin-plated (reflow treatment)
 Housing: Glass-filled LCP, Black
 Peg: Brass, nickel-undercoated, tin-plated (reflow treatment)

Male connector

Side entry type

Dual row

● 8 circuits

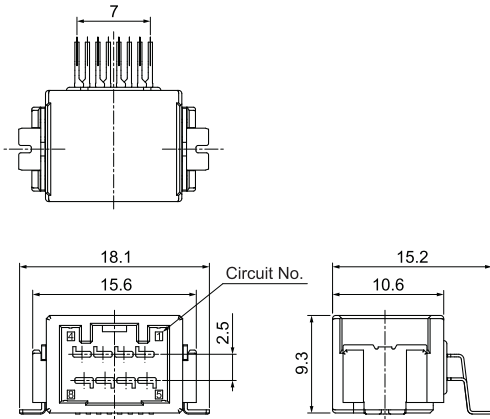

● 12 circuits

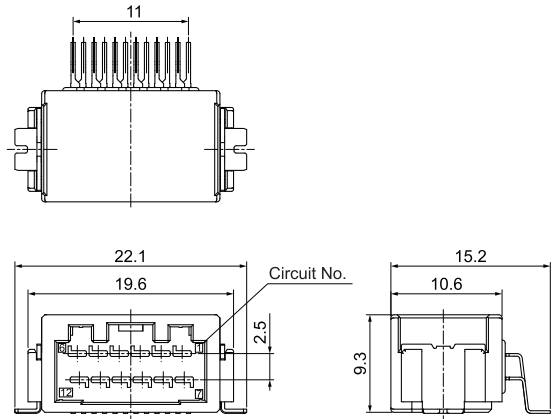

● 16 circuits

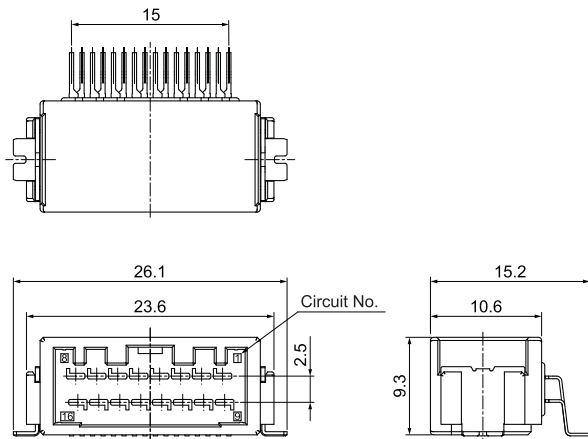

● 20 circuits

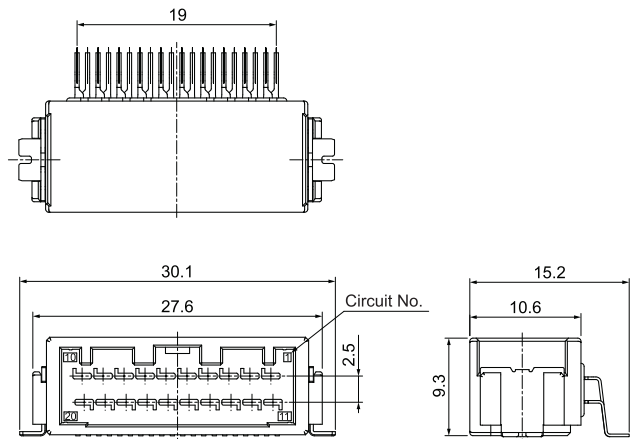

● 24 circuits

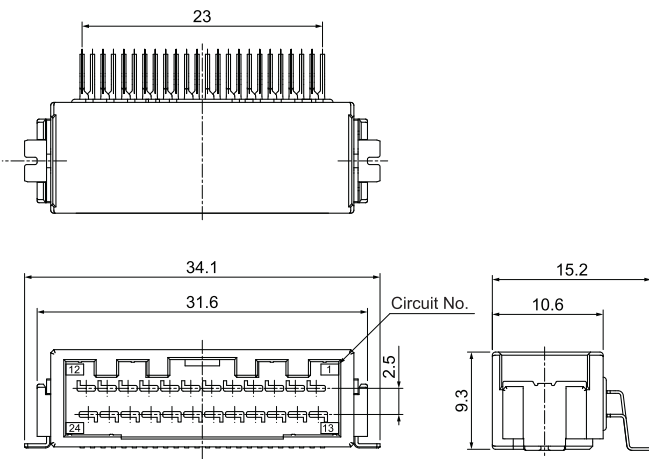

Type	Circuits	Model No.	Q'ty/reel
Side	Dual row	8	SM08B-CPTK-1A-TB
		12	SM12B-CPTK-1A-TB
		16	SM16B-CPTK-1A-TB
		20	SM20B-CPTK-1A-TB
		24	SM24B-CPTK-1A-TB
			390

Material and Finish

Terminal: Copper alloy, nickel-undercoated,
 Contact area; gold-plated
 Solder tail; tin-plated (reflow treatment)
 Housing: Glass-filled LCP, Black
 Peg: Brass, nickel-undercoated, tin-plated (reflow treatment)

CPT CONNECTOR

Taping Specifications

Top entry type

● 2, 8, 12 circuits

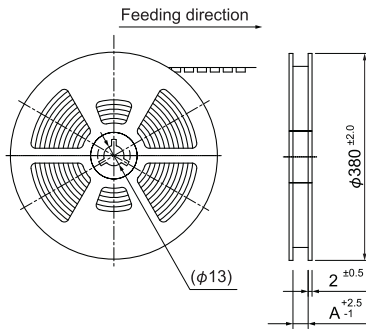

● 2 circuits

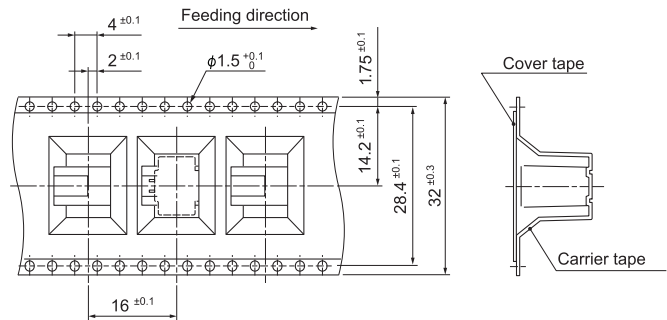

● 8, 12 circuits

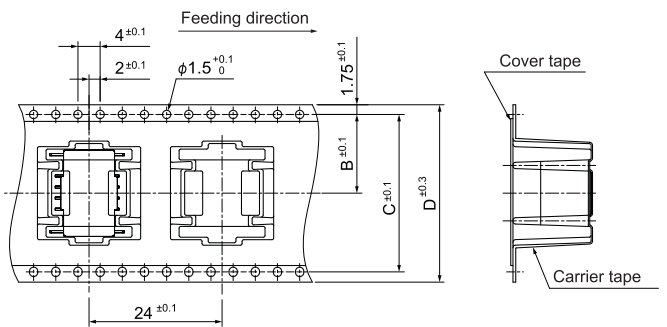
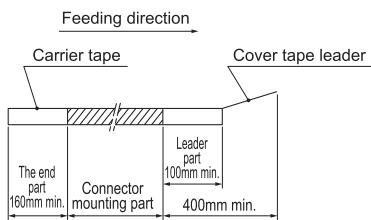

Type	Circuits	A	B	C	D
Single row	2	33.5	—	—	—
Dual row	8	33.5	14.2	28.4	32
	12	45.5	20.2	40.4	44

Side entry type

● 2, 4, 8, 12, 16, 20, 24 circuits

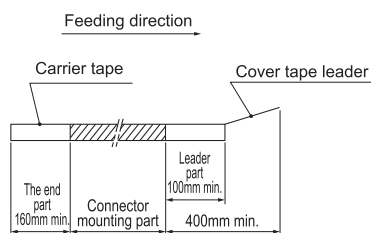
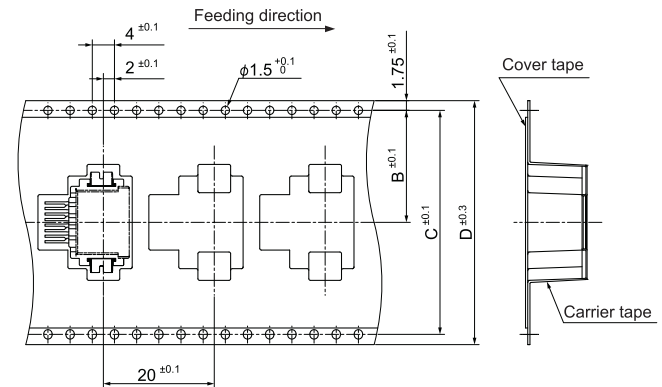
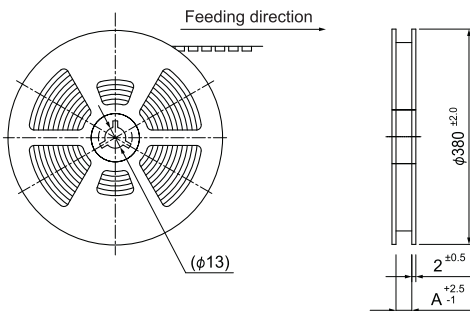

Type	Circuits	A	B	C	D
Single row	2	33.5	14.2	28.4	32
	4	33.5	14.2	28.4	32
	8	45.5	20.2	40.4	44
Dual row	8	45.5	20.2	40.4	44
	12	45.5	20.2	40.4	44
	16	45.5	20.2	40.4	44
	20	45.5	20.2	40.4	44
	24	57.5	26.2	52.4	56

PC board layout, Assembly layout

Top entry type
PC board layout
Single row
●2 circuits

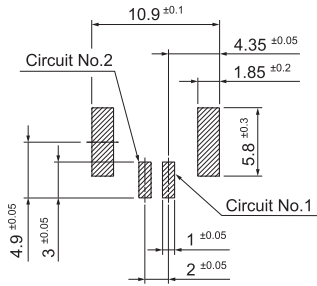

Assembly layout

●2 circuits

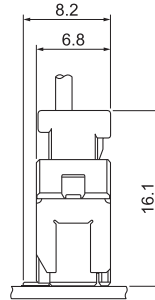

Dual row
●8, 12 circuits

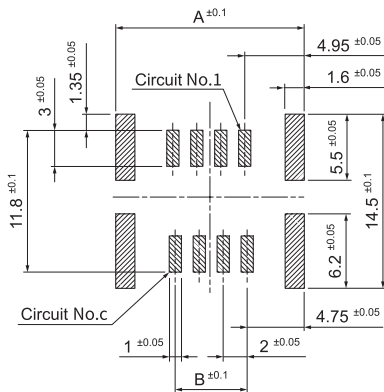

●8 circuits

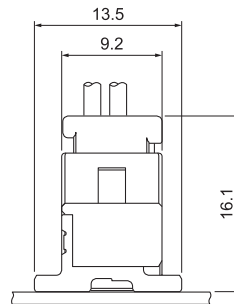

●12 circuits

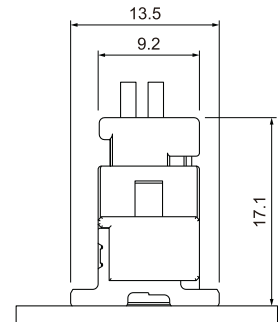

Circuits	A	B
8	15.7	6
12	19.7	10

Note: 1. Tolerances are non-cumulative: ± 0.05 mm for all centers.
 2. The dimensions above should serve as guideline. Contact JST for details.

CPT CONNECTOR

PC board layout, Assembly layout

Side entry type PC board layout Single row

● 2, 4, 8 (Single) circuits

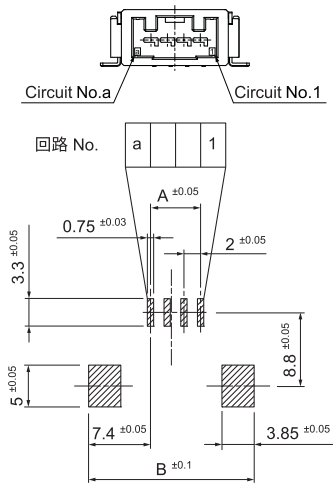

Circuits	A	B
2	2	15.8
4	6	19.8
8 (Single)	14	27.8

Assembly layout

● 2 circuits

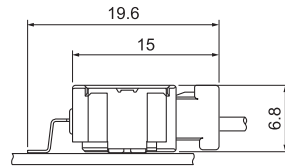

● 4 circuits

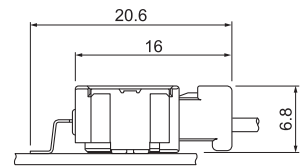

● 8 (Single) circuits

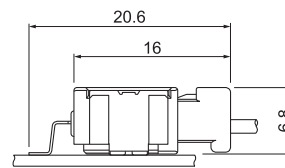

Dual row

● 8 (Dual), 12, 16, 20, 24 circuits

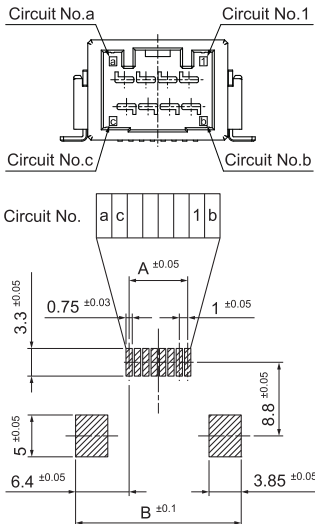

Circuits	A	B
8 (Dual)	7	19.8
12	11	23.8
16	15	27.8
20	19	31.8
24	23	35.8

● 8 (Dual) circuits

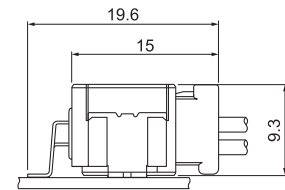

● 12 circuits

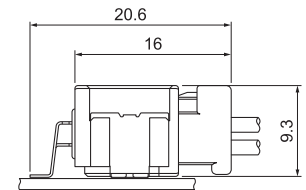

● 16 circuits

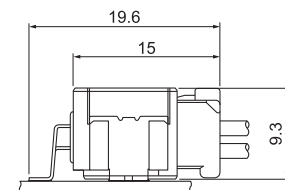

● 20, 24 circuits

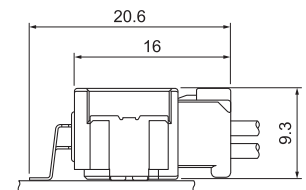

Note: 1. Tolerances are non-cumulative: ± 0.05 mm for all centers.
2. The dimensions above should serve as guideline. Contact JST for details.

Crimping machine, Applicator

Strip terminal	Crimping machine	Crimp applicator MKS-L	
		Dies	Crimp applicator with dies
SCPT-A021GF-0.5	AP-K2N	MK/SCPT-A021-05	APLMK SCPT-A021-05

Note: When crimping operation is conducted using an applicator and die set other than the above, JST cannot guarantee the performance of the terminal.