

Solderless terminals

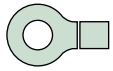

RING TONGUE (R type) Nylon-insulated (flared)

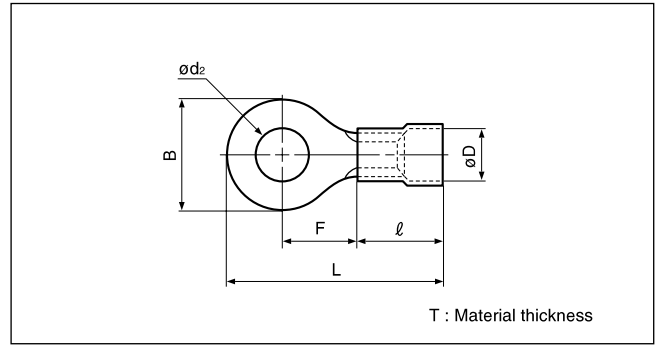
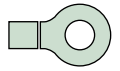

Certificate No.: E42024 LR20812 JQ0608019

Applicable Wire AWG#(mm ²)	Stud size		Part No.		Standard	Dimensions mm (in.)						Color	Tool No.	Qty/box	
	American	Metric	JST	JIS		ϕd_2	B	L	F	ℓ	ϕD				T
26 to 22 (0.2 to 0.5)	1-2	2	FN0.5-2			2.2 (.087)	5.2 (.205)	16.7 (.658)	5.8 (.228)	8.3 (.315)	2.9 (.114)	0.5 (.020)	Yellow	YNT-2622 YA-1 YA-2 BCT-0514	1,000
	3-4	3	FN0.5-3			3.2 (.126)	5.2 (.205)	16.7 (.658)	5.8 (.228)						
	5-6	3.5	FN0.5-3.7			3.7 (.146)	6.6 (.260)	19.3 (.760)	7.7 (.303)						
	8	4	FN0.5-4			4.3 (.169)	6.6 (.260)	19.3 (.760)	7.7 (.303)						
	10	5	FN0.5-5			5.3 (.209)	8.0 (.315)	19.3 (.760)	7.0 (.276)						
22 to 16 *(0.25 to 1.65)	1-2	2	FN1.25-2			2.2 (.087)	5.5 (.217)	15.7 (.618)	4.0 (.157)	9.0 (.354)	4.0 (.157)	0.8 (.031)	Red	YNT-2216 YA-1 YA-2 YA-4 BCT-0514	1,000
	3-4	3	FN1.25-3	RBC1.25-3		3.2 (.126)	5.5 (.217)	15.7 (.618)	4.0 (.157)						
	3-4	3	FN1.25-MS3			3.2 (.126)	8.0 (.315)	20.0 (.787)	7.0 (.276)						
	3-4	3	FN1.25-3.7			3.7 (.146)	5.5 (.217)	15.7 (.618)	4.0 (.157)						
	5-6	3.5	FN1.25-3.7			3.7 (.146)	5.5 (.217)	15.7 (.618)	4.0 (.157)						
	5-6	3.5	FN1.25-M3	RBC1.25-3.5		3.7 (.146)	6.6 (.260)	18.6 (.732)	6.3 (.248)						
	8	4	FN1.25-M4			4.3 (.169)	6.6 (.260)	18.6 (.732)	6.3 (.248)						
	8	4	FN1.25-4	RBC1.25-4		4.3 (.169)	8.0 (.315)	20.0 (.787)	7.0 (.276)						
	10	5	FN1.25-5	RBC1.25-5		5.3 (.209)	8.0 (.315)	20.0 (.787)	7.0 (.276)						
	1/4	6	FN1.25-6			6.4 (.252)	11.6 (.457)	25.9(1.020)	11.1 (.437)						
	5/16	8	FN1.25-8			8.4 (.331)	11.6 (.457)	25.9(1.020)	11.1 (.437)						
3/8	10	FN1.25-10		10.5 (.413)	13.6 (.535)	29.7(1.169)	13.9 (.547)								
16 to 14 (1.04 to 2.63)	1-2	2	FN2-S2			2.2 (.087)	6.4 (.252)	16.5 (.650)	4.3 (.169)	9.0 (.354)	4.5 (.177)	0.8 (.031)	Blue	YNT-1614 YA-1 YA-2 YA-4 BCT-0514	1,000
	3-4	3	FN2-MS3			3.2 (.126)	5.5 (.217)	17.4 (.685)	5.6 (.220)						
	3-4	3	FN2-S3.3			3.2 (.126)	6.4 (.252)	16.5 (.650)	4.3 (.169)						
	3-4	3	FN2-3			3.2 (.126)	8.5 (.335)	21.0 (.827)	7.8 (.307)						
	5-6	3.5	FN2-S3			3.7 (.146)	6.4 (.252)	16.5 (.650)	4.3 (.169)						
	5-6	3.5	FN2-M3	RBC2-3.5		3.7 (.146)	6.6 (.260)	18.6 (.732)	6.3 (.248)						
	5-6	3.5	FN2-P3.5			3.7 (.146)	7.0 (.276)	20.2 (.780)	7.7 (.303)						
	8	4	FN2-M4			4.3 (.169)	6.6 (.260)	18.6 (.732)	6.3 (.248)						
	8	4	FN2-P4			4.3 (.169)	7.0 (.276)	20.2 (.800)	7.7 (.303)						
	8	4	FN2-4	RBC2-4		4.3 (.169)	8.5 (.335)	21.0 (.827)	7.8 (.307)						
	10	5	FN2-M5			5.3 (.209)	8.5 (.335)	21.0 (.827)	7.8 (.307)						
	10	5	FN2-5	RBC2-5		5.3 (.209)	9.5 (.374)	21.0 (.827)	7.3 (.287)						
	1/4	6	FN2-6	RBC2-6		6.4 (.252)	12.0 (.472)	26.0(1.024)	11.0 (.433)						
	5/16	8	FN2-8	RBC2-8		8.4 (.331)	12.0 (.472)	26.0(1.024)	11.0 (.433)						
	3/8	10	FN2-10			10.5 (.413)	13.6 (.535)	29.7(1.169)	13.9 (.547)						
	1/2	12	FN2-12			13.0 (.512)	19.0 (.748)	35.2(1.386)	16.7 (.657)						
	1/2	14	FN2-14			15.0 (.591)	27.0(1.063)	43.7(1.720)	21.2 (.835)						
5/8	16	FN2-16		17.0 (.669)	27.0(1.063)	43.7(1.720)	21.2 (.835)								
3/4	20	FN2-20		21.0 (.827)	27.0(1.063)	43.7(1.720)	21.2 (.835)								
12 to 10 (2.63 to 6.64)	3-4	3	FN5.5-3			3.2 (.126)	9.5 (.374)	26.5(1.043)	8.3 (.327)	13.5 (.531)	6.8 (.268)	1.0 (.039)	Yellow	YNT-1210S YA-4 BCT-0514	500
	5-6	3.5	FN5.5-S3			3.7 (.146)	7.2 (.283)	23.0 (.906)	5.9 (.232)						
	8	4	FN5.5-S4			4.3 (.169)	7.2 (.283)	23.0 (.906)	5.9 (.232)						
	8	4	FN5.5-4	RBC5.5-4		4.3 (.169)	9.5 (.374)	26.5(1.043)	8.3 (.327)						
	10	5	FN5.5-5	RBC5.5-5		5.3 (.209)	9.5 (.374)	26.5(1.043)	8.3 (.327)						
	10	5	FN5.5-S5			5.3 (.209)	13.2 (.520)	29.1(1.146)	9.0 (.354)						
	1/4	6	FN5.5-6	RBC5.5-6		6.4 (.252)	12.0 (.472)	32.5(1.280)	13.0 (.512)						
	1/4	6	FN5.5-S6			6.4 (.252)	13.2 (.520)	29.1(1.146)	9.0 (.354)						
	5/16	8	FN5.5-S8			8.4 (.331)	13.2 (.520)	29.1(1.146)	9.0 (.354)						
	5/16	8	FN5.5-8	RBC5.5-8		8.4 (.331)	15.0 (.591)	34.7(1.366)	13.7 (.539)						
	3/8	10	FN5.5-10	RBC5.5-10		10.5 (.413)	15.0 (.591)	34.7(1.366)	13.7 (.539)						
	1/2	12	FN5.5-12			13.0 (.512)	19.2 (.756)	39.1(1.539)	16.0 (.630)						
	1/2	14	FN5.5-14			15.0 (.591)	32.0(1.260)	54.8(2.157)	25.3 (.996)						
	5/8	16	FN5.5-16			17.0 (.669)	32.0(1.260)	54.8(2.157)	25.3 (.996)						
	11/16	18	FN5.5-18			19.0 (.748)	32.0(1.260)	54.8(2.157)	25.3 (.996)						
3/4	20	FN5.5-20		21.0 (.827)	32.0(1.260)	54.8(2.157)	25.3 (.996)								

Note: 1) Products with the JIS mark conform to JIS C2805.

2) *The crimping will be more secure if the total cross-sectional area of the wire is at least 0.5 mm².

Examples: If the cross-sectional area of the wire is 0.3mm², fold the wire in two when crimping the terminal.

If the cross-sectional area of the wire is 0.5mm², crimp the terminal onto the wire as it is.

3) Because nylon absorbs moisture, care must be taken concerning storage.

4) The part numbers indicated in the above table are for products with a brazed seam,

When ordering products with a butted seam, add the prefix "WS" to the part number (ex. FN2-4 → FNWS2-4).

5) Delivery lead times may vary depending on the product. Contact JST for details.